

# SMART STORAGE.

**Cubby**



Contact us:

**Email**

arne@clubcubby.be

**Phone**

+ 32 495 790 299

**Location**

Kerkstraat 108, 9050 Gent

Cubby reimagines storage solutions, offering a range of smart and secure systems that enhance efficiency and improve daily life. From shared community resources to streamlined key management and effortless guest experiences.



# Table of content

02  
About Us

---

03  
ClubCubby

---

05  
KeyCubby

---

06  
UrbanCubby

---

# About us

## Experience Cubby

Cubby provides innovative storage solutions that are smart, secure, and user-friendly. Our products streamline access, enhance efficiency



## ClubCubby

Effortless guest storage. Enhanced security. Increased venue revenue.

## KeyCubby

Secure key storage and access. Streamline operations. 24/7 availability.

## UrbanCubby

Unlock community resources. Promote sustainability. Enhance public spaces.

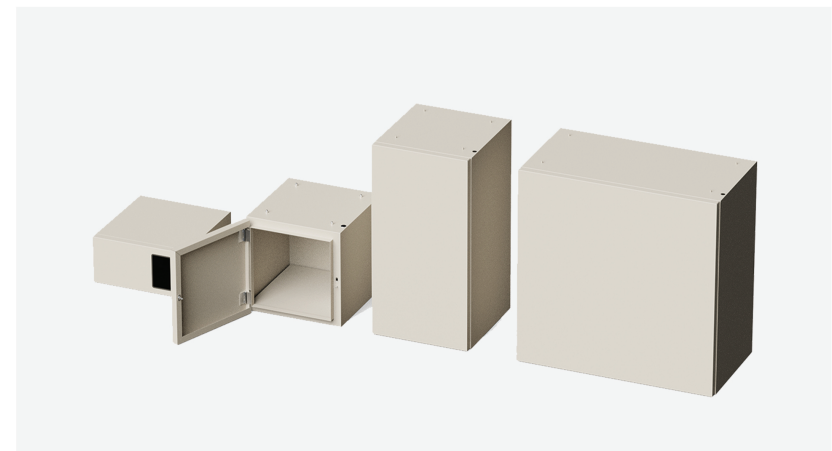
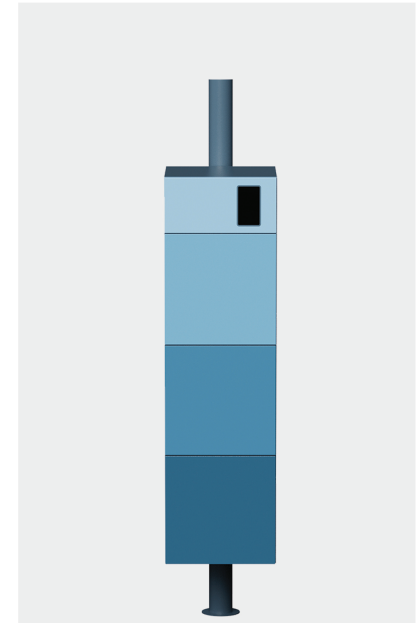



# ClubCubby

## ClubCubby

Create a seamless and enjoyable experience for your guests with ClubCubby. Our stylish and secure lockers provide convenient storage, enhancing the overall guest experience.

### Key Features of ClubCubby

**Smartphone Integration:** Instant locker access through any smartphone browser.

**Custom Branding:** Personalize or wrap lockers with your venue's branding for a cohesive look.

**Robust Durability:** Built to withstand high usage and designed for long-term reliability.

**Modular Design:** Easily add or remove locker modules to meet changing demand.

## Smart locker user guideline

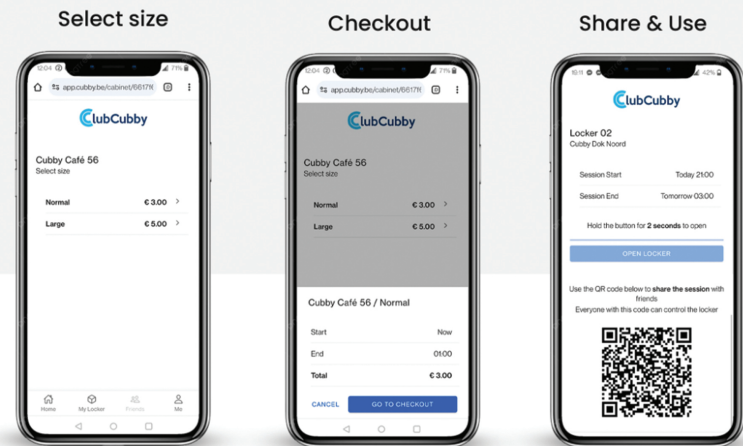



# Need a specific size?

We can customize to fit your needs.

[Contact us for details](#)

Main module type 1

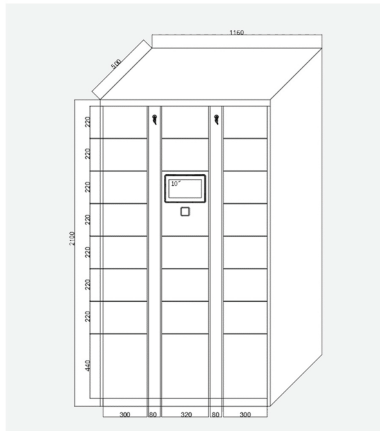

ClubCubby Render



Sub module type 2

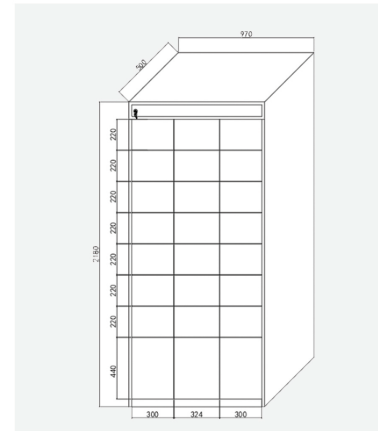

Sub module Type 2 extra

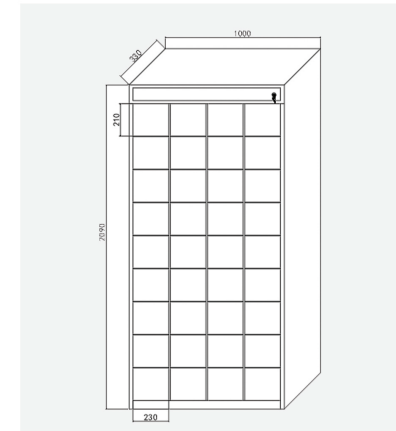

Main module type 2 extra with backpacks

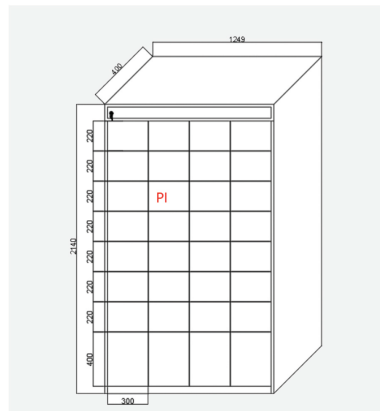

Sub module backpack

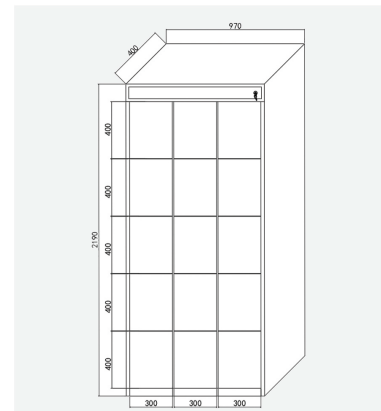

Sub module type 1

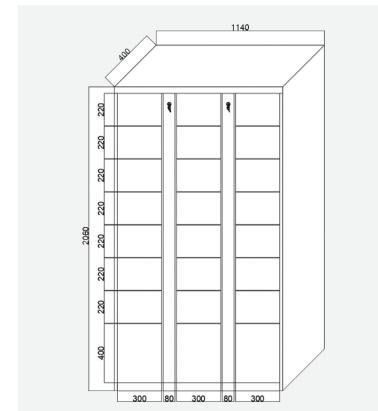

Custom size

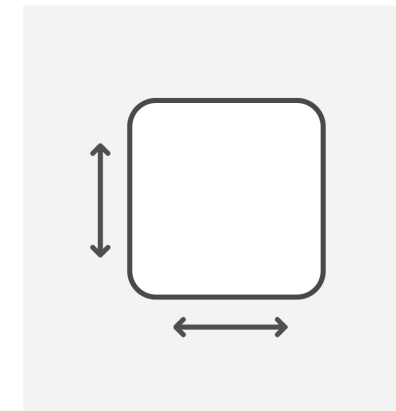

# KeyCubby

Managing keys has never been easier or more secure. KeyCubby is a state-of-the-art smart locker system designed to streamline key storage, access, and management for property managers, car rental companies, shared workspaces, and more. Say goodbye to lost keys and time-consuming manual processes—KeyCubby is here to revolutionize the way you handle keys.

---

## How KeyCubby Works

- 1. Smartphone Access:** Users receive a unique code to access their assigned KeyCubby.
- 2. Secure Storage:** Keys are stored safely inside tamper-proof lockers.
- 3. Cloud Monitoring:** Administrators can track all activity in real time through the cloud-based management system.
- 4. Easy Return:** Users return keys to the locker and complete the process with another QR scan.

## Key Features of KeyCubby

**Cloud-Based Control:** Monitor and manage all locker activity in real time via our web application.

**Access Logs:** Maintain a full record of who accessed which keys and when, providing accountability and transparency.

**Customizable Configurations:** Choose locker sizes and layouts tailored to your needs.

**Smartphone Integration:** No app downloads required—users can access lockers via a web browser.

**Tamper-Proof Design:** Built with robust materials to ensure security and durability.

**Open API:** Integrate with existing reservation systems via our open API.



# UrbanCubby

## Revolutionizing Smart Storage for the Sharing Economy

UrbanCubby is more than just a locker system— it's a transformative platform designed to make sharing, sports, and public space management more efficient and accessible. Our modular, LEGO-like smart lockers empower individuals, organizations, and communities to embrace sustainability.

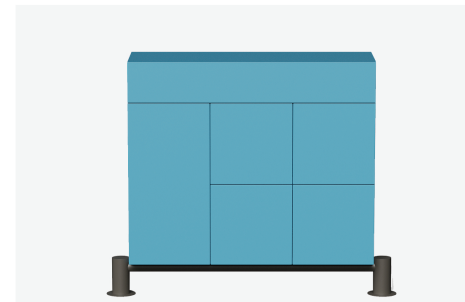
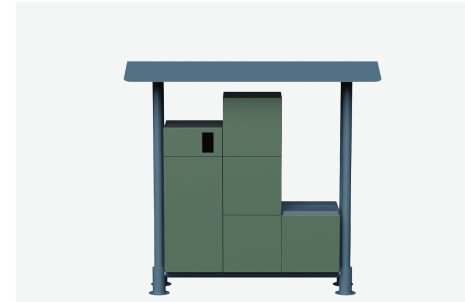

## Use Cases and Impact

### Public Sharing Initiatives:

UrbanCubby supports local governments in enabling sharing projects like library of things, fostering sustainability and promoting the sharing economy.

### Sports & Recreation Facilities:

Enhance the user experience with autonomous equipment management, saving on operational costs and improving service.

### Private & Corporate Solutions

Companies can improve employee well-being by offering shared sports equipment or resources during breaks, boosting engagement and productivity.

# UrbanCubby

## UrbanCubby Visuals

UrbanCubby is more than just a locker system— it's a transformative platform designed to make sharing, sports, and public space management more efficient and accessible. Our modular, LEGO-like smart lockers empower individuals, organizations, and communities to embrace sustainability and convenience.

Contact us, and let's build your UrbanCubby together!

